

Clarke®

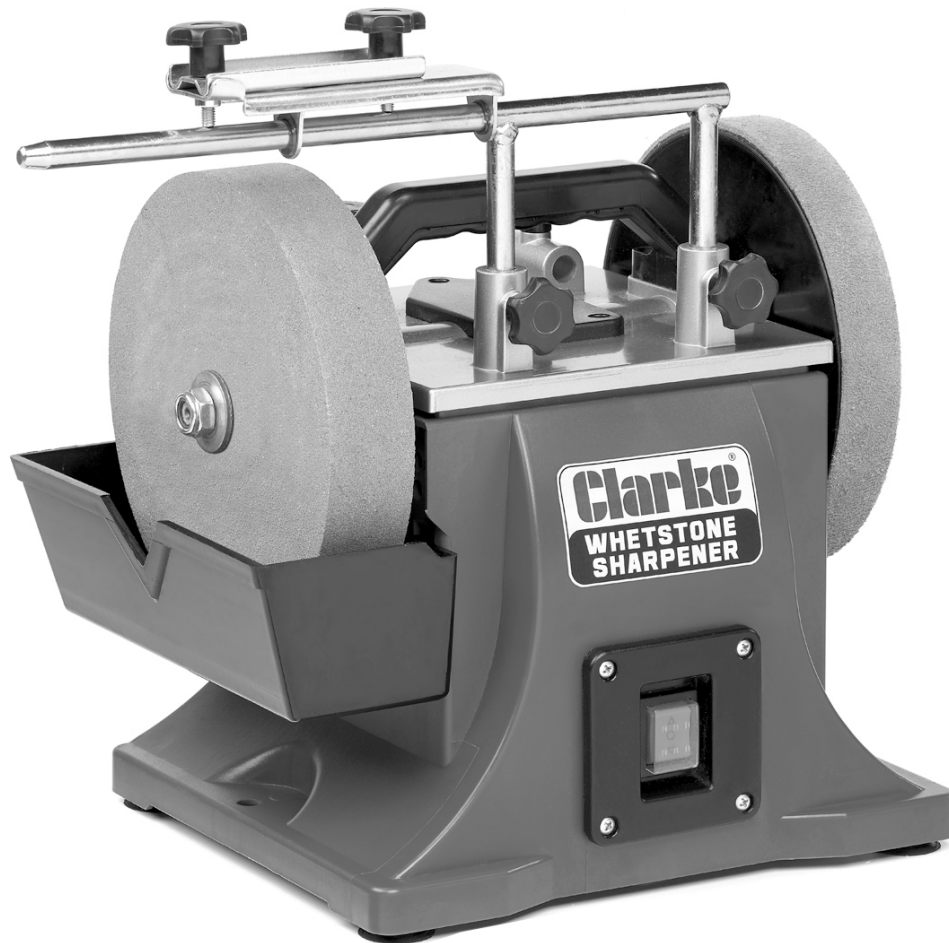

WHETSTONE SHARPENER

MODEL NO: CWS200B

PART NO: 6500531

OPERATING & MAINTENANCE INSTRUCTIONS



UK
PA | CE

ORIGINAL INSTRUCTIONS

DL1022 - ISS 4

INTRODUCTION

Thank you for purchasing this CLARKE Whetstone Sharpener.

Before attempting to use this product, please read this manual thoroughly and follow the instructions carefully. In doing so you will ensure the safety of yourself and that of others around you, and you can look forward to your purchase giving you long and satisfactory service.

GUARANTEE

This product is guaranteed against faulty manufacture for a period of 12 months from the date of purchase. Please keep your receipt which will be required as proof of purchase.

This guarantee is invalid if the product is found to have been abused or tampered with in any way, or not used for the purpose for which it was intended.

Faulty goods should be returned to their place of purchase, no product can be returned to us without prior permission.

This guarantee does not effect your statutory rights.

ENVIRONMENTAL PROTECTION



Do not dispose of this product with general household waste. All tools, accessories and packaging should be sorted, taken to a recycling centre and disposed of according to the laws governing Waste Electrical and Electronic Equipment.

Through the purchase of this product, the customer is taking on the obligation to deal with the WEEE in accordance with the WEEE regulations in relation to the treatment, recycling & recovery and environmentally sound disposal of the WEEE.

In effect, this means that this product must not be disposed of with general household waste. It must be disposed of according to the laws governing Waste Electrical and Electronic Equipment (WEEE) at a recognised disposal facility.

GENERAL SAFETY RULES



CAUTION: FAILURE TO FOLLOW THESE PRECAUTIONS COULD RESULT IN PERSONAL INJURY, AND/OR DAMAGE TO PROPERTY.

WORK ENVIRONMENT

1. Keep the work area clean, tidy and well lit. Cluttered and dark areas invite accidents
2. Do not operate power tools in explosive atmospheres, such as in the presence of flammable liquids, gases or dust. Power tools create sparks which may ignite the dust or fumes.
3. Keep children and bystanders away while operating a power tool. Distractions can cause you to lose control.

PERSONAL SAFETY

1. Stay alert, watch what you are doing and use common sense when operating a power tool. Do not use a power tool while you are tired or under the influence of drugs, alcohol or medication. A moment of inattention while operating power tools may result in personal injury.
2. Avoid accidental starting. Ensure the switch is in the off position before plugging in. Plugging in power tools that have the switch on invites accidents.
3. Do not overreach. Keep proper footing and balance at all times. This enables better control of the power tool in unexpected situations.
4. Dress properly. Do not wear loose clothing or jewellery. Keep your hair, clothing and gloves away from moving parts. Loose clothes, jewellery or long hair can be caught in moving parts.
5. Gloves, manufactured to the current European safety standards should be worn when operating grinding equipment.
6. Eye protection manufactured to the current European safety standards should be worn when operating grinding equipment. Eye protectors must provide protection from flying particles from the front and the side.

GENERAL USE AND CARE OF POWER TOOLS

1. ALWAYS check for any damage or condition that could affect the sharpener's operation. Any damaged part should be properly repaired.
2. NEVER use the sharpener if it is defective or operating abnormally.

3. NEVER abuse the mains cable. Never yank the cable to disconnect it from the socket. Keep the cable away from sharp edges/hot surfaces.
4. NEVER carry out any alterations or modifications to this product.
5. NEVER wipe the sharpener clean with solvents. Wipe plastic parts with a soft cloth, slightly dampened with soapy water.
6. NEVER attempt any repairs yourself. If you have a problem with this product contact your local CLARKE dealer.
7. Do not use the tool for any purpose than that described in this manual.
8. Always maintain the tool with care. Keep it clean for the best and safest performance.
9. Do not force the power tool. Use the correct power tool for your application. The correct power tool will do the job better and safer at the rate which it was designed.
10. Do not use the power tool if the switch does not turn it on and off. Any power tool that cannot be controlled with the switch is dangerous and must be repaired.
11. Store idle tools out of the reach of children and do not allow persons unfamiliar with the power tool or these instructions to operate the power tool. Power tools are dangerous in the hands of untrained users.
12. Maintain power tools. Check for misalignment or binding of moving parts, breakage of parts and any other condition that may affect the power tools operation. If damaged, have the power tool repaired before use. Many accidents are caused by poorly maintained power tools.
13. Use the power tool and accessories in accordance with these instructions and in the manner intended for the particular type of power tool, taking into account the working conditions and the work to be performed. Use of the power tool for operations different from intended could result in a hazardous situation.

ELECTRICAL SAFETY

1. Power tool plugs must match the outlet. Never modify the plug in any way. Do not use adapter plugs with earthed (grounded) power tools. Correct plugs and matching outlets will reduce the risk of electric shock.
2. Do not abuse the cable. Never use it for carrying, pulling or unplugging the power tool. Keep the cable away from heat, oil, sharp edges or moving parts. Damaged or entangled cables increase the risk of electric shock.
3. Do not expose power tools to rain or wet conditions. Water entering a power tool will increase the risk of electric shock. If operating the power tool in a damp location is unavoidable, use a residual current device (RCD) protected supply.

4. When operating a power tool outdoors, use an extension cable suitable for outdoor use. Use of a cable suitable for outdoor use reduces the risk of electric shock.

GRINDING STONE SAFETY

1. Check the speed of the grindstone before fitting to your grinder. Never use a stone with a rpm speed less than the rpm speed of your grinder. See specification.
2. The outside diameter and thickness of your accessories must be within the capacity rating of the power tool. The correct size accessories can be correctly guarded and controlled.
3. Never use a stone that is chipped, cracked or damaged. Fragments from a broken or damaged grinding stone can cause serious injury. Make sure that defective stones are destroyed and not used.
4. Bonded abrasive products are breakable and shall therefore be handled with utmost care. The use of damaged or improperly mounted or used abrasive products is dangerous and can cause serious injuries.
5. Always refer to the label for specified usage and observe the safety information. Do not use for purposes other than specified.
6. Always use the correct stone for it's intended task. Using the incorrect stone can cause serious injury.
7. Allow the stone and tool to do the work. Never force the workpiece against the stone as this could cause kickback and/or shatter the stone causing serious injury.
8. Do not use separate reducing bushes or adapters to adapt large hole abrasive wheels. Do not force a stone onto a machine or alter the size of the arbor hole.
9. Never use a damaged grinding stone. Inspect the stone before each use for chips, cracks or excess wear. If the tool or accessory is dropped, inspect for damage or install a new accessory. After fitting the accessory, position yourself away from the plane of the rotating accessory and run the tool at full speed. damaged stones may break apart during this test.
10. Abrasive products shall be handled and transported with care. Abrasive products shall be stored in such a manner that they are not subjected to mechanical damage and harmful environmental influences.

SHARPENER SAFETY WARNINGS

1. Hold a hand tool or blade being sharpened firmly to prevent loss of control.
2. Never install a abrasive flap wheel or sanding disc on this sharpener.
3. Always replace a cracked grinding wheel immediately.

4. Never use damaged or incorrect grindstones. The stone and retaining fixtures were specially designed for your grinder, for optimum performance and safety of operation. Inspect the condition of the grinding stone before use and do not use if any damage is found.
5. Always use the tool rests to steady the workpiece. If the tool attachments are not used, the torque of the spinning grinding/polishing wheel may pull the workpiece from your hands.
6. Never leave the sharpener unattended when it is connected to an electrical power supply. Switch off the machine and unplug it before leaving.
7. ALWAYS check for damaged parts. Before further use any part that is damaged should be carefully checked to determine if it would operate properly and perform its intended function. Check for misalignment or binding of moving parts, breakage of parts and any other condition that may affect the tool's operation. A part that is damaged should be properly repaired or replaced at an authorised service center. Following this rule will reduce the risk of electric shock, fire or serious injury.

NOTE: Bench grinders/sharpeners used in industrial environments may be subject to the requirements of The Provision and Use of Work Equipment regulations 1992 (particularly regarding the training requirement of The Abrasive Wheels Regulations 1970), or other legislation. If in doubt seek advice.

Please keep these instructions in a safe place for future reference.

SAFETY SYMBOLS

The meanings of the markings and symbols on the product are shown below

	Read this manual before use and keep in a safe place for future reference		Wear eye protection when using this sharpener.
	Gloves should be worn when grinding.		Wear dust mask when using the sharpener or honing wheel.

ELECTRICAL CONNECTIONS



WARNING! READ THESE ELECTRICAL SAFETY INSTRUCTIONS THOROUGHLY BEFORE CONNECTING THE PRODUCT TO THE MAINS SUPPLY.

Before switching the product on, make sure that the voltage of your electricity supply is the same as that indicated on the rating plate. This product is designed to operate on 230VAC 50Hz. Connecting it to any other power source may cause damage.

This product may be fitted with a non-rewireable plug. If it is necessary to change the fuse in the plug, the fuse cover must be refitted. If the fuse cover becomes lost or damaged, the plug must not be used until a suitable replacement is obtained.

If the plug has to be changed because it is not suitable for your socket, or due to damage, it should be cut off and a replacement fitted, following the wiring instructions shown below. The old plug must be disposed of safely, as insertion into a mains socket could cause an electrical hazard.



WARNING! THE WIRES IN THE POWER CABLE OF THIS PRODUCT ARE COLOURED IN ACCORDANCE WITH THE FOLLOWING CODE: BLUE = NEUTRAL BROWN = LIVE YELLOW AND GREEN = EARTH

If the colours of the wires in the power cable of this product do not correspond with the markings on the terminals of your plug, proceed as follows.

- The wire which is coloured **Blue** must be connected to the terminal which is marked **N** or coloured **Black**.
- The wire which is coloured **Brown** must be connected to the terminal which is marked **L** or coloured **Red**.
- The wire which is coloured **Yellow and Green** must be connected to the terminal which is marked **E** or  or coloured **Green**.

Plug must be BS1363/A approved.

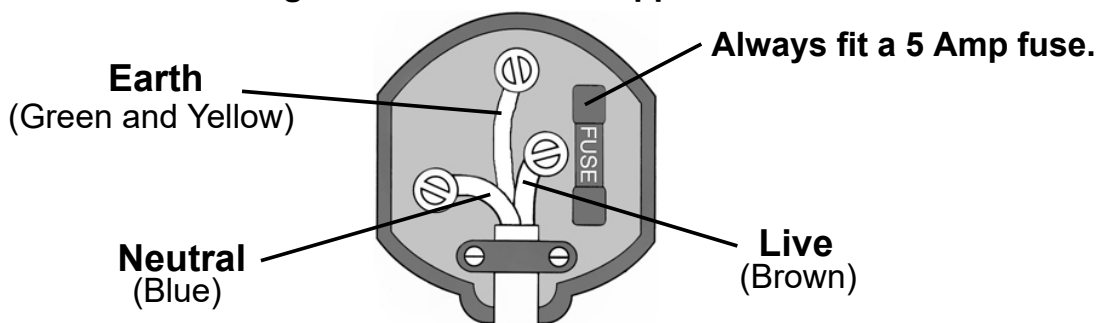

Ensure that the outer sheath of the cable is firmly held by the clamp

We strongly recommend that this machine is connected to the mains supply via a Residual Current Device (RCD). If in any doubt, consult a qualified electrician. DO NOT attempt any repairs yourself.

OVERVIEW

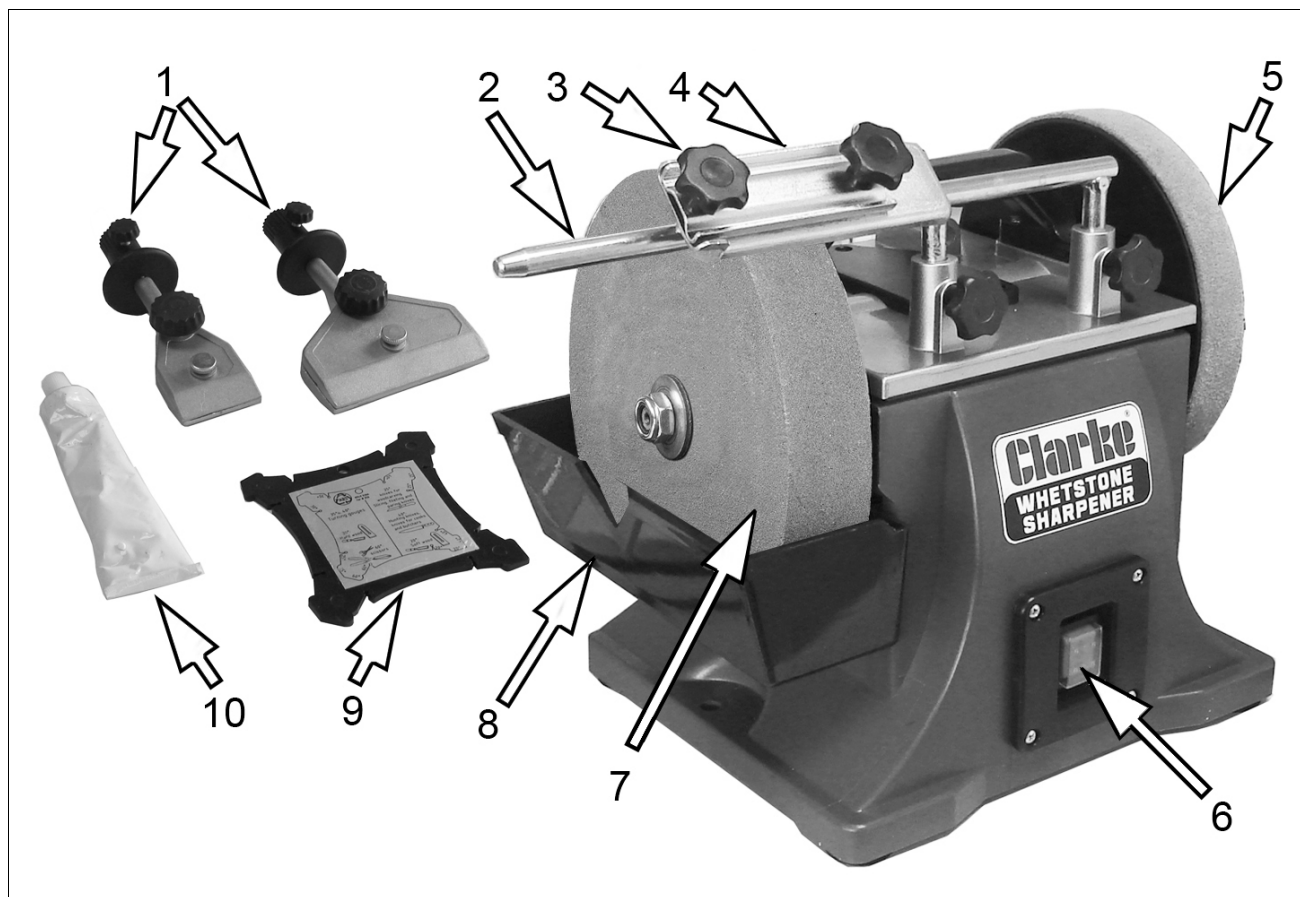

No	Description
1	Knife Holders
2	Tool Support
3	Fixing Knob
4	Tool Clamp
5	Honing Wheel

No	Description
6	On/Off Switch
7	Grinding Wheel
8	Water Trough
9	Angle Guide
10	Tube of Abrasive Paste

The items above should be supplied in the carton. If any items are missing or damaged, please contact the Clarke dealer where you purchased the product.

Position the machine in good light, and fixed to a suitable workbench using the boltholes in the machine base. It is designed to be operated from either side, depending upon the grinding or honing operation.

BEFORE USE

FITTING THE TOOL SUPPORT

1. Insert the tool support into the two mounting holes at the top of the grinder as shown.
 - The tool support can be used to support the grinding jigs/ clamps, a truing or dressing tool, or as a tool or hand rest when working without jigs.

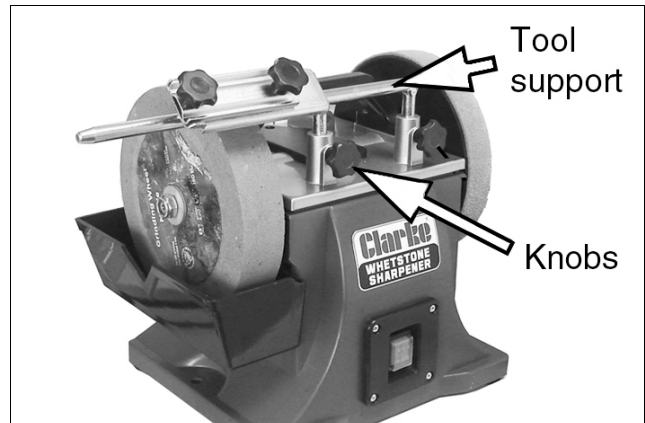

VERTICAL GRINDING/HONING

1. Adjust the tool support to the desired height, before tightening the two knobs to secure it in position.

HORIZONTAL GRINDING

1. Attach the tool support by inserting into the two mounting holes located on the rear of the grinder. Adjust to the desired height, before tightening the two knobs to secure it as shown.
2. Plug the machine into the nearest power supply.
3. Attach the water trough beneath the grinding stone. Fill the water trough with clean water up to the cut-out on the trough.
 - The grinding stone must run in water at all times during operation and will become soaked with water.
4. Ensure the water trough is re-filled when necessary and discard any excess particles of stone which have accumulated in the water trough after extensive use.

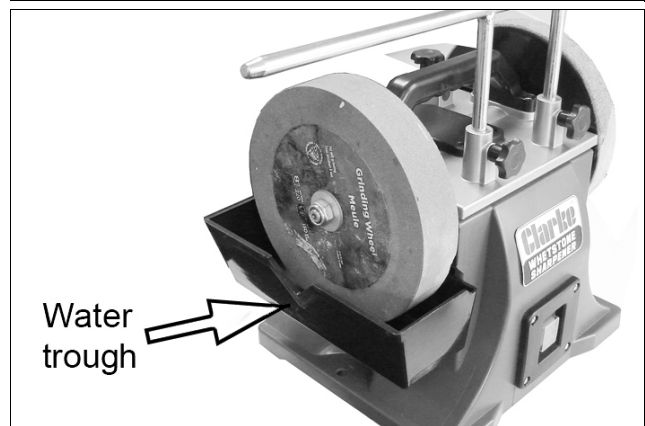
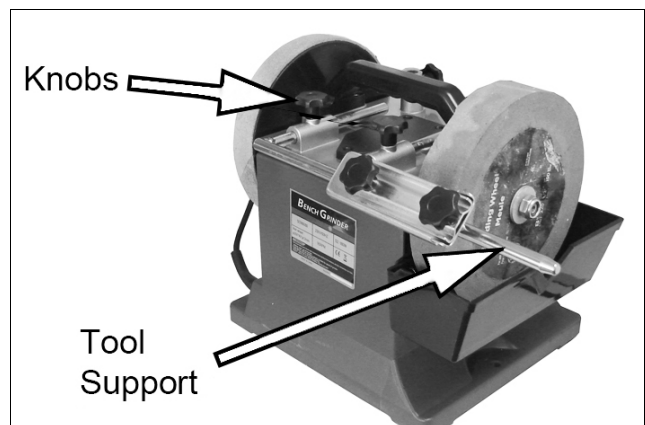

5. To start/stop the grinder, press the ON/OFF switch.

- The grinder can run either forwards or backwards, selectable via a 3-position rocker switch.

Press the switch 'up' for reverse rotation (anti-clockwise when viewed from the grinding wheel end).

Press the switch 'down' for forward rotation (clockwise when viewed from the grinding wheel end).

6. Distribute the abrasive paste evenly onto the honing wheel with a suitable tool as shown.

7. This should be sufficient for five to ten tool honing tasks. This process should be repeated as required to ensure the long life of the honing wheel and achieve a good finish.

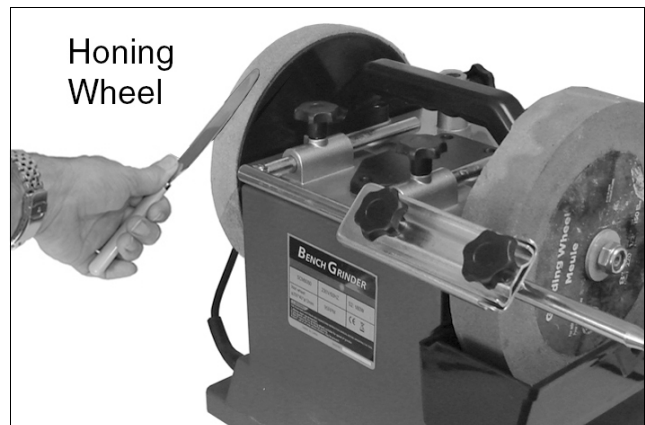
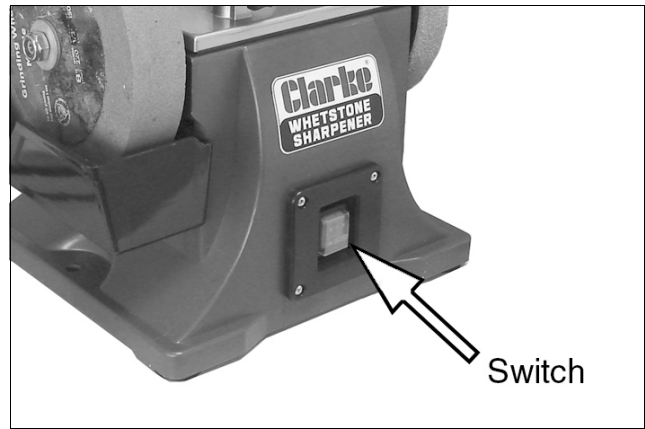

USING YOUR GRINDER



WARNING: FRAGMENTS FROM A BROKEN/DETACHED GRINDING WHEEL CAN CAUSE INJURY.

WARNING: ENSURE THAT THE WORKING POSITION ADOPTED DOES NOT CAUSE OPERATOR FATIGUE WHICH MAY LEAD TO LOSS OF CONTROL OF THE TOOL BEING GROUND.

WARNING: THE STONE WILL CONTINUE TO ROTATE BRIEFLY AFTER THE SWITCH HAS BEEN PRESSED.

GETTING STARTED

The tool support can be used to support the tool clamp or be used for freehand grinding of any tools such as axes, pocket knives or woodcarving chisels that will not fit into the available tool holders.

USING THE TOOL CLAMP

The tool clamp is designed for sharpening chisels and plane blades etc. When using the tool holder proceed as follows.

1. Slide the tool clamp onto the tool support.
2. Position the clamp directly above the grinding stone or honing wheel. Loosen the two knobs on the tool clamp. Insert the tool blade (bevelled end downwards) in the tool clamp, then firmly tighten the blade in position as shown.

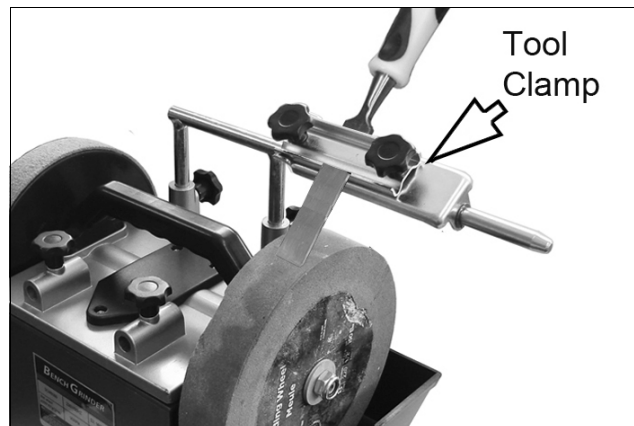

3. Adjust the tool support so that the tool clamp is a suitable distance from the grinding stone or honing wheel. Loosen the two knobs on the tool clamp to adjust the tool blade so that its edge lightly touches the grinding stone or honing wheel. The correct angle will be determined by using the Angle Guide as described below.
4. Switch on the grinder and slowly move the tool clamp back and forth along the tool support to grind the tool blade. If necessary, loosen the knobs on the tool clamp to re-adjust the blade. After adjustment, check that the angle is still correct.

USING THE ANGLE GUIDE

1. The angle guide is used to determine the cutting edge angle of a tool. To do so, secure the tool into the tool clamp, then install the clamp to the tool support as shown.
2. With the machine switched off, hold the angle guide with the desired angle (as indicated on the angle guide) at the tool tip.

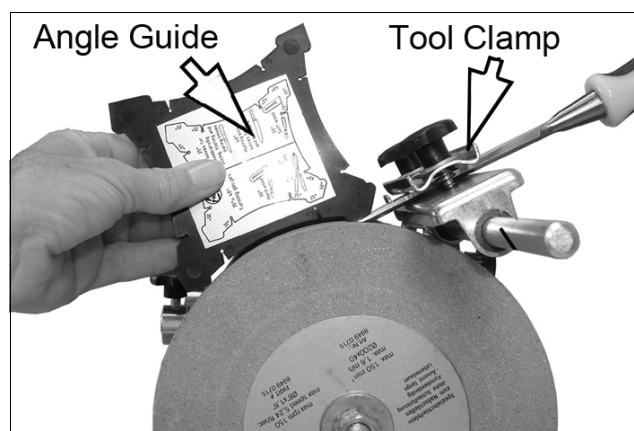

3. Adjust the height of the tool support so that the front end of the angle guide, touches the grinding stone. Make sure the angle guide continues to touch the tool tip.
4. Once the desired angle is achieved, firmly lock the tool support in place and remove the angle guide.

GRINDING/HONING A KNIFE BLADE

Two knife holders are supplied for sharpening knives of different lengths and stiffness. Knives will be sharpened with an equal bevel to each side of the blade as itemized on the angle guide.

When using the knife holders proceed as follows:

1. Loosen the knurled screw on the knife holder. Centre the tension plate along the top edge of the knife blade then firmly tighten the knurled screw to set the knife blade in position.
2. Tighten the knob to secure the knife blade tightly before starting work.
3. Set the knife holder on the tool support and adjust the tool support bar downward so that the knife blade lightly touches the grinding stone or honing wheel at the correct angle as determined by the angle guide.
4. Turn on the sharpener and grasp the knife holder firmly. Place the holder on the tool support and slowly move the knife holder back and forth along the tool support to grind/hone the knife blade. Steady your hand against the tool support as you work. The process will be repeated for the other side after resetting the knife in the holder.

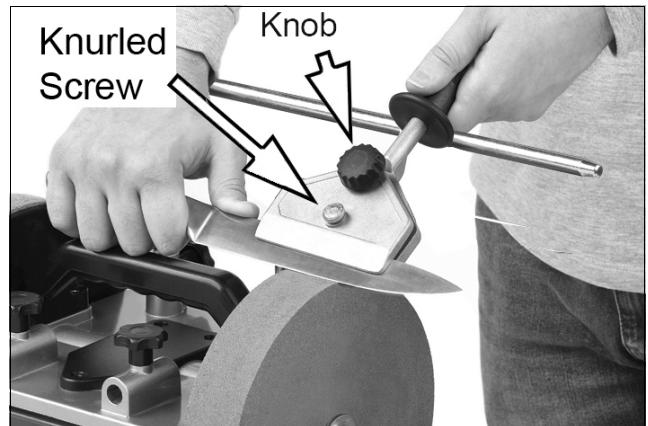

GRINDING TIPS

- After setting the angle, switch on the grinder and start work.
- Press the tool blade evenly onto the stone and move the tool sideways across the stone. Make sure that at least half the width of the tool cutting edge comes into contact with the sharpening stone at any time to avoid damage to the stone.
- Allow the stone to do the work. Do not apply excessive downward pressure on the tool when grinding.
- Make sure the level of water in the tank is adequate. Never attempt to dry grind.

HONING TIPS

- Never hone against the direction of the honing wheel, which would cause the tool to cut into the leather honing wheel surface.
- Although you can work "freehand" for the honing process, you will achieve more precise results by

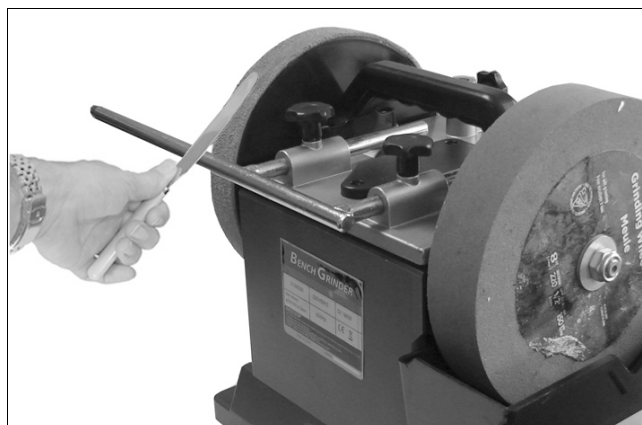

securing the tool with the tool clamp or tool holder, and setting the honing angle to the angle used when grinding the tool.

- Press the tool evenly onto the honing wheel near the cutting edge, and move the tool sideways across the wheel. Ensure that at least half the width of the cutting edge comes into contact with the wheel at any time to avoid damage to the wheel.
- Allow the wheel to do the honing, without applying excessive downward pressure on the tool.
- Always ensure the honing wheel is kept saturated with machine oil and abrasive paste for best results.

TROUBLESHOOTING

PROBLEM	CAUSE	SOLUTION
Grinder will not operate.	No power supply.	Check supply & rectify.
	ON/OFF switch is faulty.	Consult your CLARKE dealer.
	Fuse blown.	Check & replace if necessary. Consult your dealer if condition persists.
	Motor faulty.	Consult your CLARKE dealer.
Motor runs but wheel not spinning.	Retaining nut not tight.	Ensure wheel is correctly seated. Tighten retaining nut. See Maintenance on page 14.
	Honing wheel not engaged with drive pin.	Loosen wheel & engage wheel on drive pin. See page 15.
Motor gets too hot.	Wrong supply voltage.	Ensure supply voltage is correct.
	Work load too heavy.	Reduce pressure applied to work-piece.
Unusual vibration while working.	Grindstone mounted incorrectly or damaged.	Check & rectify. Replace grinding wheel immediately.
	Bearings badly worn.	Consult your CLARKE dealer.

MAINTENANCE

GENERAL MAINTENANCE

Make sure that all components are tight and secure.

Always have any damaged or worn parts repaired or replaced by qualified service personnel. Do not attempt to repair the grinder unless you are qualified to do so.

The drive motor and bearings are sealed units and require no regular maintenance. Should you require assistance, contact your local Clarke service agent.

The honing wheel may develop a bump after extensive use where the glued joint in the leather covering stands proud as the leather becomes compressed. This can be corrected by sanding away the high spot with an abrasive (sandpaper) block.

The stone will wear down with use and may well go out of true. Use a dressing wheel or stone grader to correct the trueness and to remove worn, glazed grains from the stone.

The stone will have a finite life expectancy, dependant upon the nature of the work being done. Periodically, make a note of the wheel diameter and replace your 8" (200mm) dia wheel if it reduces to an little as 7" (180mm) in diameter.

INSTALLING A NEW GRINDING STONE

1. Unscrew and remove the locknut and washer that secures the stone in place.
2. Remove the old grinding stone and fit the replacement, securing it with the locknut and washer. Grasp the honing wheel to prevent the drive shaft from turning while tightening the nut.

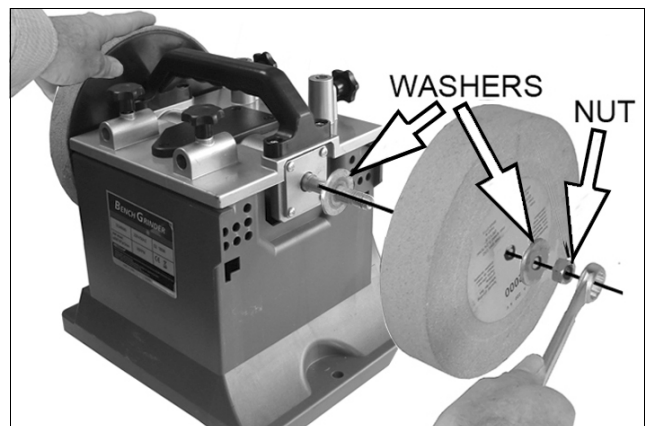

DRESSING A NEW STONE

New grinding stones are frequently not true or in time can become grooved, glazed (built-up), out of round or otherwise mis-shapen. To correct these defects, a grinding stone dresser is available from your Clarke dealer.

ET125 Grinding Wheel Dresser - Part No:1700225

Replacement Dresser Wheel - Part No:1700230

ET154 ½ Carat Diamond Tip Wheel Dresser - part No:1700329

1. If the grinding stone is new, allow it to spin for a minute with no load. Check that it is spinning straight and true. If not, it will require dressing before use.
2. Stand to the side of the stone and hold the dresser handle firmly. Place the dresser on the tool support so that its wheels can move freely (i.e, the exposed part of the wheel should be facing up). Run the stone and apply the dresser to the surface of the stone.

INSTALLING A NEW HONING WHEEL

1. Unscrew and remove the hand nut and washer that secures the honing wheel in place.
2. Remove the old honing wheel and fit the replacement, securing it with the hand nut and washer. Ensure the drive pin, rests in the groove in the hidden face of the honing wheel.

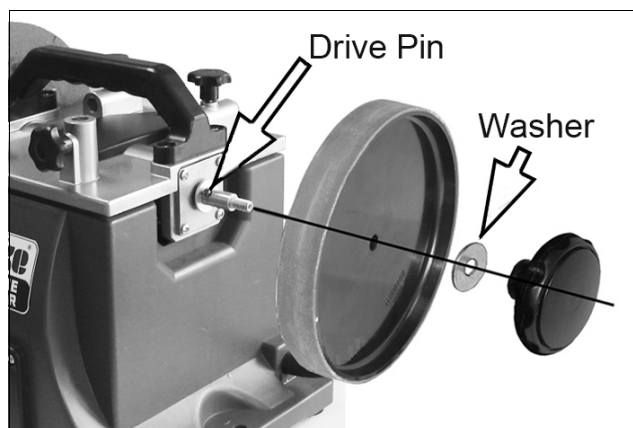

CLEANING & STORAGE

Clean the exterior the machine if required using a mild detergent or mild solvent. Never immerse the machine in water.

To reduce any fire hazard, keep the cooling vents below the grinder free of debris.

If not bolted to a workbench, store the grinder in a clean, dry location, out of reach of children.

SPECIFICATIONS

Feature	Value
Product Dimensions (L x W x H)	255 x 343 x 303 (excl work support) mm
Weight	11.1 kg
Grinding Stone Dimensions (D x T)	200 x 40 mm (12 mm bore)
Honing Wheel Dimensions (D x T)	200 x 30 mm (12.5 mm bore)
IP Rating	20
Rated Voltage / Frequency	230 V / 50 Hz
Motor Wattage	180 W
Input Ampere (typical load)	0.78 A
No Load Speed	95 rpm
Duty Cycle Classification	S2 (30 min)
Sound pressure	61.6 dB (A)
Sound Power Measured (Lwa dB)	73.4 Lp A

DECLARATION OF CONFORMITY



Hemnal Street, Epping, Essex CM16 4LG

DECLARATION OF CONFORMITY

This is an important document and should be retained.

We hereby declare that this product(s) complies with the following statutory requirement(s):

Electromagnetic Compatibility Regulations 2016
Supply of Machinery (Safety) Regulations 2008
The Restriction of the Use of Certain Hazardous Substances in Electrical & Electronic Equipment Regulations 2012

The following standards have been applied to the product(s):

EN 55014-1:2017, EN 55014-2:2015, EN IEC 61000-3-2:2019, EN 61000-3-3:2013 + A1:2019,
EN 62841-1:2015, EN 62841-3-4:2016 + A11:2017 + A12:2020, EN 62321-1:2013, EN 62321-2:2014,
EN 62321-3-1:2014, EN 62321-4:2014, EN 62321-5:2014, EN 62321-6:2015, EN 62321-7-1:2015,
EN 62321-7-2:2017, EN 62321-8:2017

The technical documentation required to demonstrate that the product(s) meet(s) the requirement(s) of the aforementioned legislation has been compiled and is available for inspection by the relevant enforcement authorities.

The UKCA mark was first applied in: 2022

Product Description: 200mm Whetstone Sharpener
Model number(s): CWS200B
Serial / batch Number: N/A
Date of issue: 26/09/2022

Signed:

J.A. Clarke
Director



Fitzwilliam Hall, Fitzwilliam Place, Dublin 2

DECLARATION OF CONFORMITY

This is an important document and should be retained.

We hereby declare that this product(s) complies with the following directive(s):

2004/30/EC Electromagnetic Compatibility Directive.
2006/42/EC Machinery Directive.
2011/65/EU Restriction of the Use of Certain Substances in Electrical & Electronic Equipment (RoHS) Directive
2015/863/EU RoHS Amendment Directive

The following standards have been applied to the product(s):

EN 55014-1:2017, EN 55014-2:2015, EN IEC 61000-3-2:2019, EN 61000-3-3:2013 + A1:2019,
EN 62841-1:2015, EN 62841-3-4:2016 + A11:2017 + A12:2020, EN 62321-1:2013, EN 62321-2:2014,
EN 62321-3-1:2014, EN 62321-4:2014, EN 62321-5:2014, EN 62321-6:2015, EN 62321-7-1:2015,
EN 62321-7-2:2017, EN 62321-8:2017

The technical documentation required to demonstrate that the product(s) meet(s) the requirement(s) of the aforementioned directive(s) has been compiled and is available for inspection by the relevant enforcement authorities.

The CE mark was first applied in: 2015

Product Description: 200mm Whetstone Sharpener
Model number(s): CWS200B
Serial / batch Number: N/A
Date of issue: 26/09/2022

Signed:

J.A. Clarke
Director

COMPONENT PARTS DIAGRAM

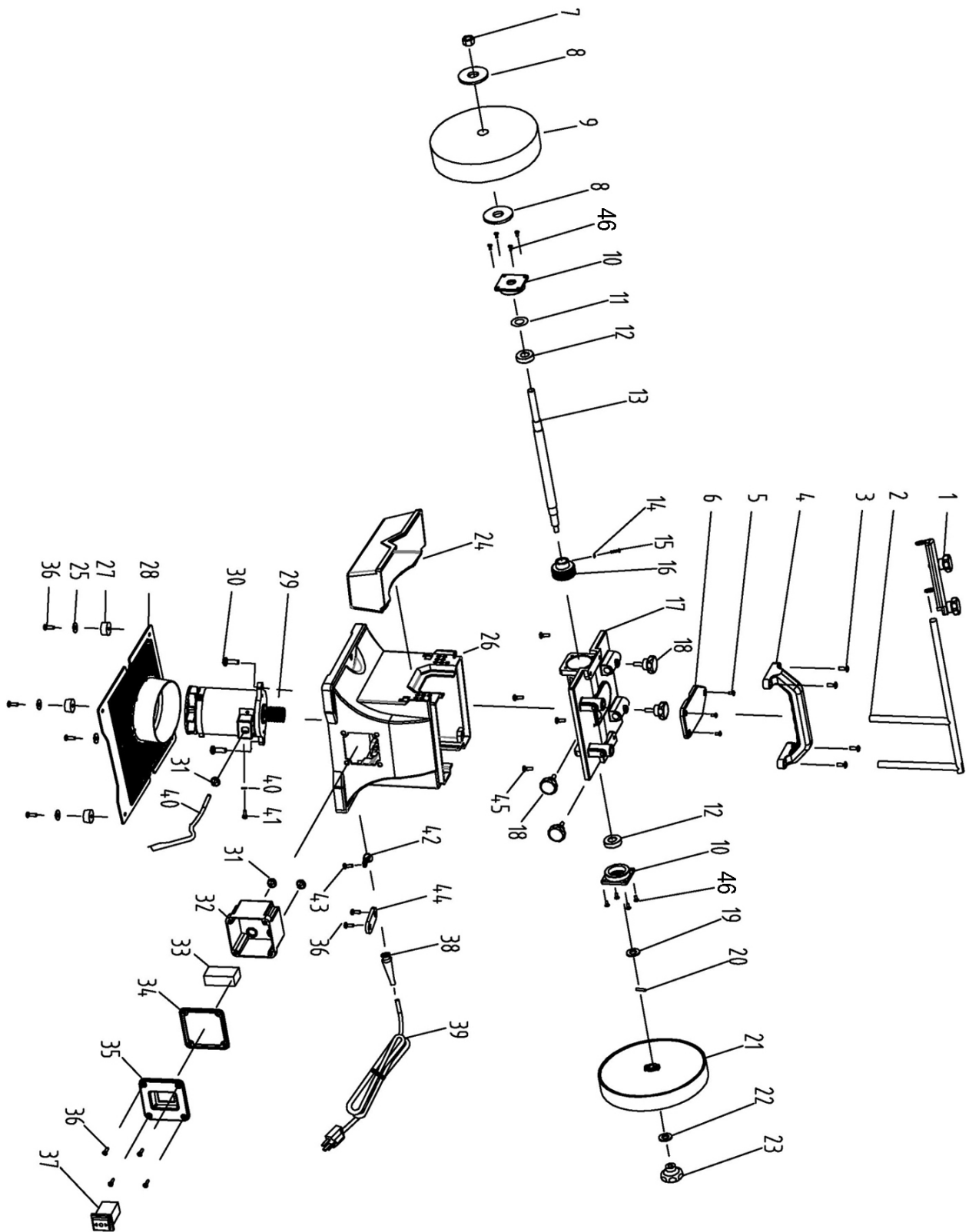

COMPONENT PARTS LIST

No	Description
1	Tool Clamp
2	Tool Support
3	Screw/flat washer/spring washer
4	Handle
5	Screw M4 x 8
6	Gearbox Cover
7	Locknut
8	Retaining Washer
9	Grinding Wheel
10	Bearing Holder
11	Wave Washer
12	Bearing 6002RZ
13	Main Shaft
14	Spring Washer
15	Screw
16	Worm Gear
17	Gearbox
18	Screw Knob
19	Washer
20	Roll Pin
21	Honing Wheel
22	Retaining Washer
23	Locking Knob

No	Description
24	Water Trough
25	Flat Washer
26	Base Frame
27	Rubber Foot
28	Base Plate
29	Motor Assembly
30	Screw/flat washer/spring washer
31	Strain Gland
32	Connecting Box
33	Capacitor
34	Rubber Gasket
35	Switch Baseplate
36	Screw
37	2-way Switch
38	Cable Sheath
39	Power Cable & Plug
40	3-core cable
41	Screw/flat washer/spring washer
42	Power Cable Clip
43	Screw
44	Cable Clamp
45	Screw/flat washer/spring washer
46	Screw M4 x 10

A SELECTION FROM THE VAST RANGE OF

Clarke®

QUALITY PRODUCTS



AIR COMPRESSORS
From DIY to industrial, Plus air tools, spray guns and accessories.

GENERATORS
Prime duty or emergency standby for business, home and leisure.

POWER WASHERS
Hot and cold, electric and engine driven - we have what you need

WELDERS
Mig, Arc, Tig and Spot. From DIY to auto/industrial.

METALWORKING
Drills, grinders and saws for DIY and professional use.

WOODWORKING
Saws, sanders, lathes, mortisers and dust extraction.

HYDRAULICS
Cranes, body repair kits, transmission jacks for all types of workshop use.

WATER PUMPS
Submersible, electric and engine driven for DIY, agriculture and industry.

POWERTOOLS
Angle grinders, cordless drill sets, saws and sanders.

STARTERS/CHARGERS
All sizes for car and commercial use.



PARTS & SERVICE:

0208 988 7400

Parts Enquiries

Parts@clarkeinternational.com

Servicing & Technical Enquiries

Service@clarkeinternational.com

SALES: UK 01992 565333 or Export 00 44 (0)1992 565335

Clarke® INTERNATIONAL Hemnall Street, Epping, Essex CM16 4LG
www.clarkeinternational.com